

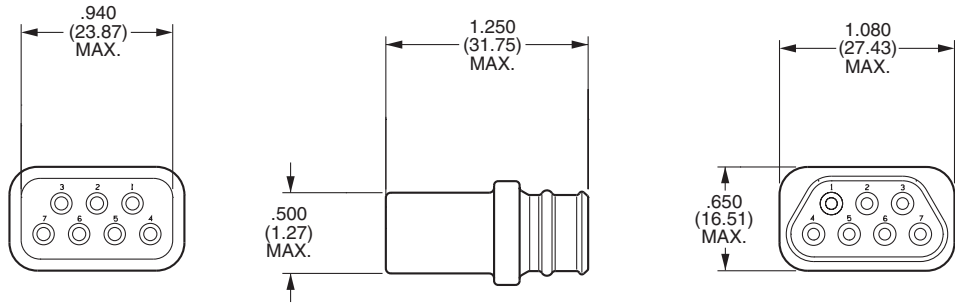

Rectangular Sure-Seal® Connector



Part Number
120-1873-007



Part Number
120-1874-007

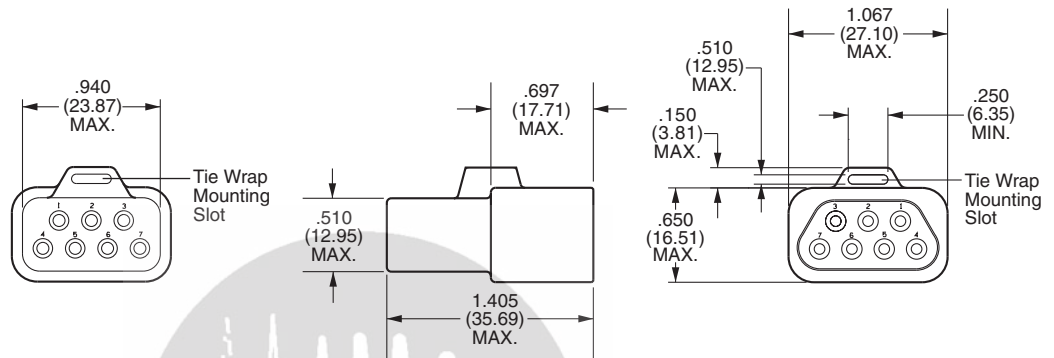

Accessories

Sealing Screws

Sealing screws are designed with a groove underneath the head to incorporate an O-ring. When tightened, the O-ring is compressed against the connector flange to form an air, water, and gas-tight seal. Sealing screws are used in conjunction with the nut plates below.

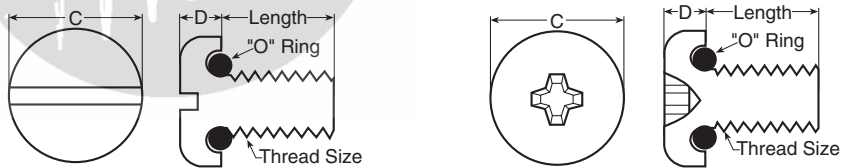

(S) Slotted Pan Head

(R) Phillips Pan Head

Part Number	Thread	Length	C Max	D Max	Clear Hole	
					Min	Max
S440-1/2	4-40NC-2A	1/2"	.220"	.069"	.125"	.129"
R440-1/2	4-40NC-2A	1/2"	.238"	.080"	.125"	.129"

Nut Plates

Nut plates should be used in conjunction with mounting plates. Nut plates eliminate the need for loose nuts which are often difficult to negotiate in confined areas. As well, they effectively distribute the screw tension across the back of the panel. The bracket is aluminum alloy with Alodine plating, and the nuts are steel alloy plated cadmium. Nut plates mate with above sealing screws.

Nut Plate P/N (uses 4-40 screws)	For Sure-Seal P/Ns
M85528/2-14A	120-8552-200
	120-8552-201
	120-8552-202
M85528/2-18A	120-8552-305
	120-8552-306
	120-8552-307

